

HeatWave™ SERIES



FEATURES

- High grade butyl diaphragm
- Two part polyurethane, epoxy primed paint finish
- Leak free, o-ring sealed air valve cap
- Comprehensive testing
- ISO:9001, GOST, CE/PED approved

HeatWave™ tanks are the quality solution for hydronic expansion. HeatWave™ tanks are built to the same stringent standards as the PressureWave™ and Challenger™ tanks.

The expansion tank, pipes and your connections if installed incorrectly could leak water. Install the expansion tank in a location where any water leak will not cause damage. The manufacturer is not responsible for any water damage in connection with this expansion tank.

With an incorporated hex nut system connection, HeatWave™ tanks are easy to install. Its air chamber sealed with a brass air valve and o-ring sealed air cap will provide many years of leak free and service free life. Its two part polyurethane, epoxy primed paint finish will withstand the harshest indoor and outdoor climates throughout the world. HeatWave™ tanks are quality tested at several stages on the production line to insure the structural integrity of every tank.

The HeatWave expansion tank is designed to be either supported by the system piping, the wall mounting bracket (inline models) or freestanding (vertical models w/ base) See reverse side for recommended piping procedures.

SPECIFICATIONS HeatWave™ Series Models

Model #'s		Nominal Volume		Shipping (box) Volume		Shipping (box) Weight		Dimensions					
Old Part Number	New Part Number	liter	gal	cu. M	cu. ft	kilos	lbs	A		B		C	
								cm	inches	cm	inches	cm	inches
HW2	HWB-2LX	2	0.5	0.004	0.14	1.1	2.4	20.8	8.2	12.6	5.0		
HW8	HWB-8LX	8	2.1	0.014	0.49	2.2	4.9	31.3	12.3	20.2	8.0		
HW12	HWB-12LX	12	3.2	0.023	0.81	2.9	6.4	36.5	14.4	23	9.1		
HW18	HWB-18LX	18	4.8	0.029	1.02	3.8	8.4	36.7	14.4	27.9	11.2		
HW24	HWB-24LX	24	6	0.042	1.48	4.9	10.8	44.7	17.6	29	11.4		
HW35	HWB-35LX	35	9.2	0.058	2.05	6.7	14.8	48.1	18.9	31.8	12.5		
HW60V	HWB-60LV	60	14	0.102	3.60	10.8	23.8	60.2	23.7	38.9	15.3	10	3.9
HW80V	HWB-80LV	80	20	0.134	4.73	15.3	33.7	79.7	31.4	38.9	15.3	10	3.9
HW100V	HWB-100LV	100	26.4	0.168	5.93	18.2	40.1	78.6	30.9	43	16.9	12.9	5.1

Factory pre-charge: HWB-2LX-HWB-24LX 0.7 bar/ 12 psi - HWB-35LX 1 bar/15psi - HWB60LV-HWB-100LV 1.5 bar/ 22 psi

Maximum Working Temperature: 210°F / 99°C

Maximum working pressure 150 psi/10bar

System Connection: Steel 3/4" BSP - Steel 1" BSP

Wall mounting bracket kits

BR200	HWB-8LX
BR280	HWB-18LX
BR290	HWB-24LX
BR320	HWB-35LX
BR390	HWB-60LV, HWB-80LV, HWB-100LV

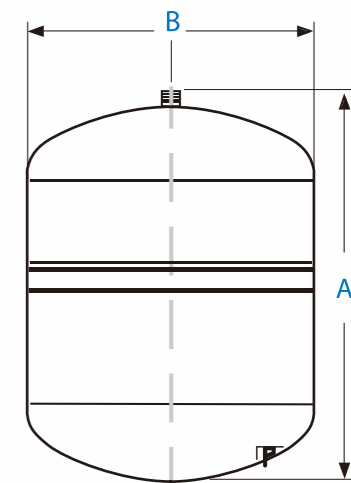

ISO:9001 CE PC03 NSF